



AZD104 - NOVEL WAY OF PIR SENSING

Reference design for a multi-sensor PIR application with ProxFusion®

1 Introduction

The IQS62x ProxFusion® IC's can be configured as a multifunctional Pyroelectric Infrared Radial (PIR) sensor. This configuration can be used for applications such as energy efficient occupancy detection applications by means of movement detection. Other features of the ProxFusion® IC's include capacitive prox/touch sensing, inductive sensing, ambient light measurements and hall effect sensors. These features can be combined with the PIR sensors for energy efficient lighting and room occupation applications.

2 Typical Uses

- > Room occupancy detection
- > Lighting Applications
- > Alarm Systems
- > Smart Home Systems

3 ProxFusion® multi-sensor solutions

As seen in Figure 3-1, the IQS62x ProxFusion® IC's can be configured as a multifunctional Pyroelectric Infrared Radial (PIR) sensor.

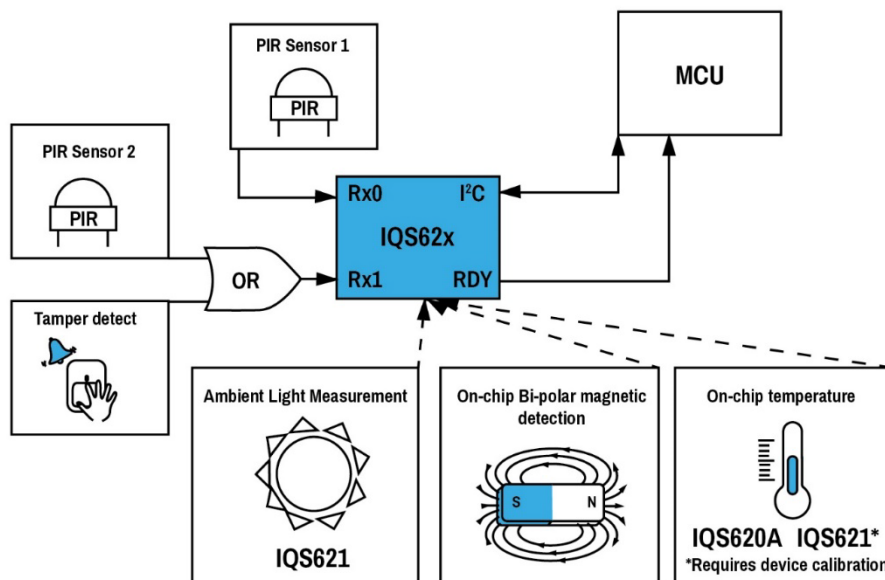

Figure 3-1: IQS62x Multifunctional PIR Sensor

The ProxFusion® IC's all have the same measurement engine for capacitive measurements. This engine is used to sample the PIR sensor. Different solutions are available and can be seen in Table 3-1. The extra capacitive channel on the IQS62x series can be used for tamper detection on the device. If two PIR sensors are required in an application, the second capacitive



prox/touch channel will be used for the second PIR sensor. I.e. one PIR and one capacitive channel or two PIR channels and no capacitive channel.

Table 3-1: ProxFusion® multi-sensor solutions

ProxFusion® IC	Package	PIR	Capacitive Prox/Touch	Hall-Effect	Temperature
IQS620A	DFN10/ WLCSP9	✓	✓	✓	✓
IQS624	DFN10	✓	✓	✓	

*Requires calibration at device production

4 PIR Sensor(s) Reference Schematics

Figure 4-1 shows the reference schematic for the IQS62x connected with two PIR elements (SENBA Optoelectronic - D203S). A PIR sensor from Murata (IRA-S210ST01) with lens pair (IML-0685) can also be used with the ProxFusion® IC's as seen in Figure 4-2. The following features should be considered when designing a PIR PCB:

4.1 General Considerations:

1. PIR elements should be connected to the CRx pins of the IQS62x.
2. The PIR element can be powered from 3V and the range of the PIR element is dependent on the supply voltage of the PIR sensor.
3. Resistors **R12**, **R16**, **R13** and **R17** is calculated based on the bias current requirement of the PIR element.
4. An RC filter is placed at the output of each PIR element to ensure stability.

4.2 Electromagnetic Interference (EMI) Considerations:

1. The PIR sensors need to be placed as close as possible to the IQS62x to decrease EMI.
2. Noise suppression components can be added if a problem is experienced with noise. These components can be changed based on the noise requirements of the application and is not compulsory.
3. The power supply to the PIR should be completely stable for accurate movement detection. A small change in the voltage or current may cause false triggers.
4. **R4** and **R5** needs to be added if the PIR sensor cannot be placed close to the IC.
5. The IQS62x have some debouncing on-chip but if the PIR is exposed to excessive noise, it is possible to implement a debounce algorithm on the MCU.



IQS62x

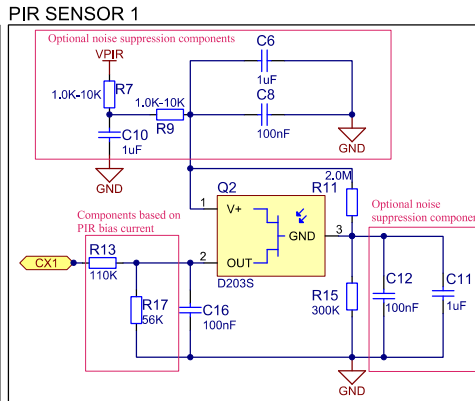
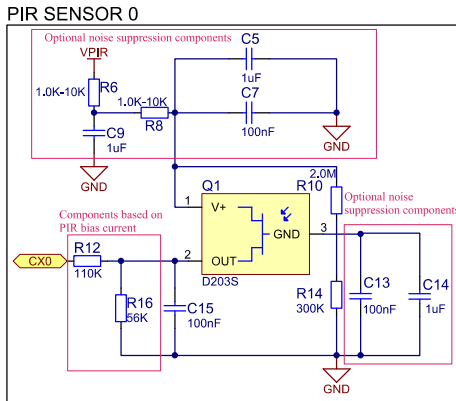
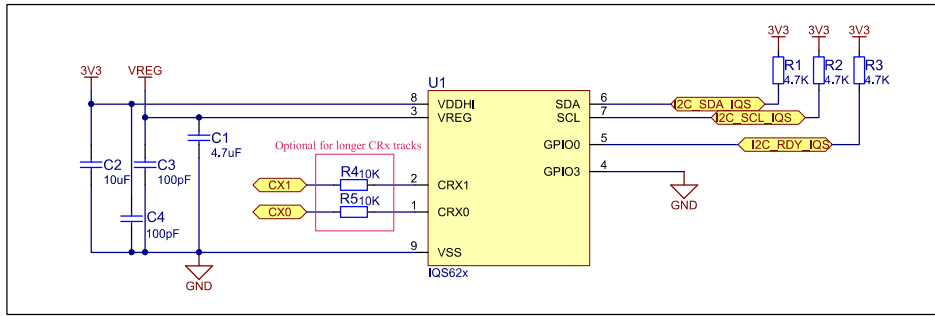

Figure 4-1: IQS62x and D203S (SENBA Optoelectronic)

IQS62x

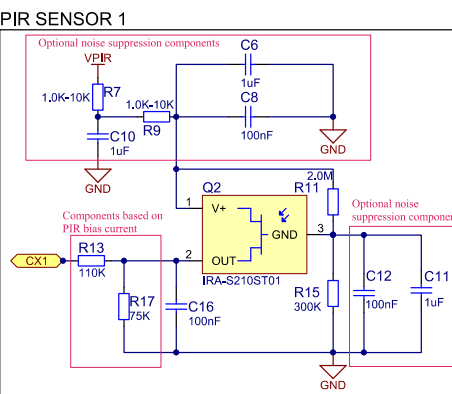
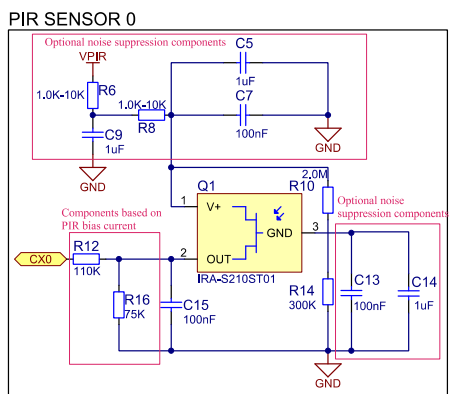
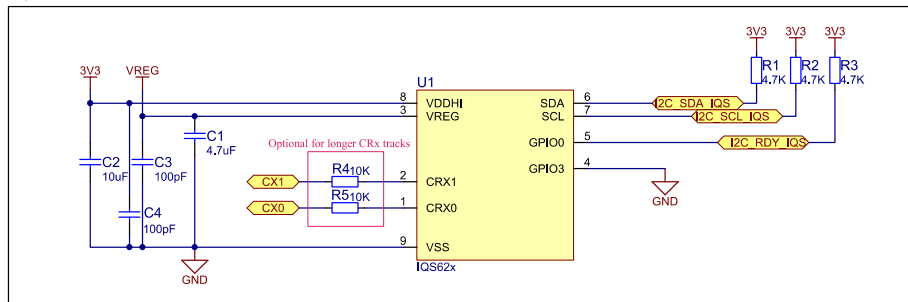

Figure 4-2: IQS62x and IRA-S210ST01



5 Fresnel Lenses

The field of view and range of the PIR application is dependent on the type of lens used. A Fresnel lens is used to project the IR on the PIR elements as seen in Figure 5-1.

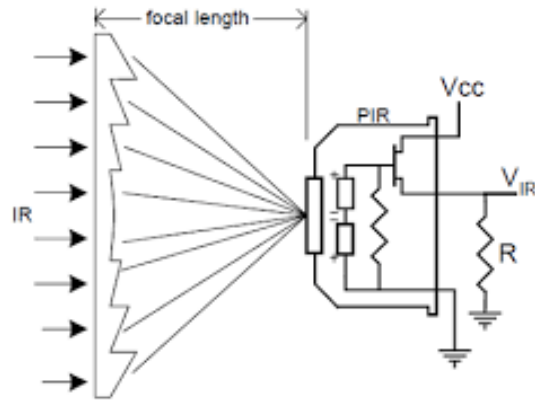

Figure 5-1: PIR Fresnel Lens

The focal length of the lens should be chosen to suite the PIR element for optimal results. Different Fresnel lenses suite different applications as seen in Figure 5-2. I.e. a wall switch pattern will look different than a ceiling mount pattern.

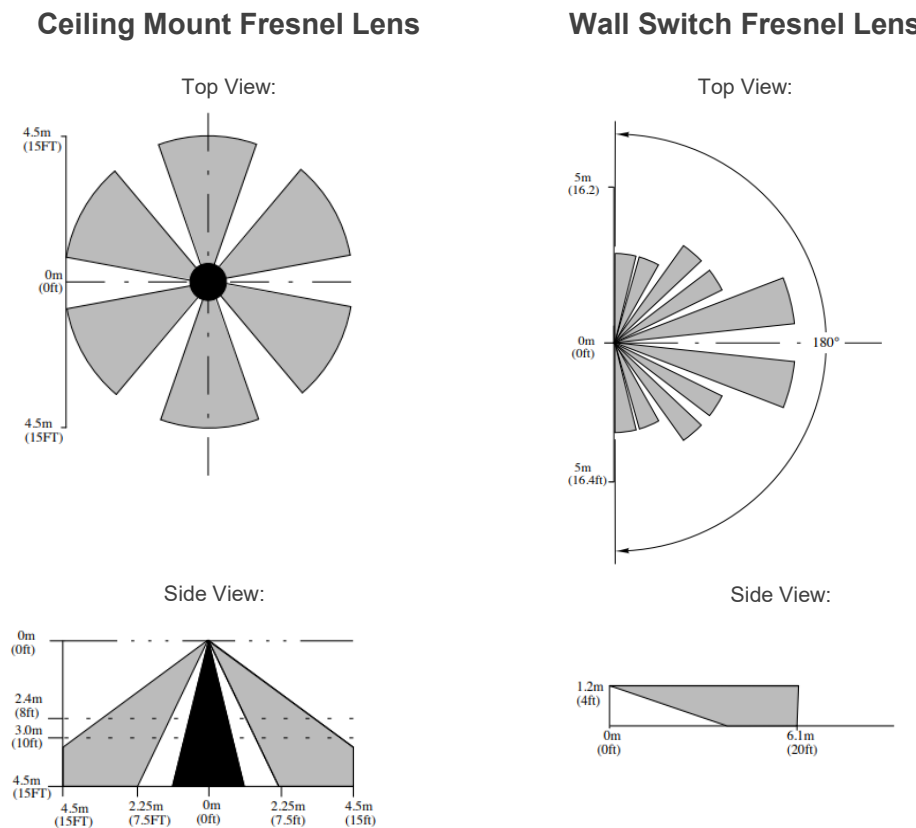

Figure 5-2: Different Fresnel Lenses (Adapted from: www.fresneltech.com)



6 ProxFusion® Advantages

The IQS62x series have several advantages over conventional PIR sensing circuitry:

- Raw data output for smart DSP algorithm
- Adjustable sensitivity (gain) via I2C
- Less components required
- Smaller PCB and less PCB layers required
- Multiple features (PIR/tamper detection/magnetic switch) on one IC
- Two PIR elements using one IC
- Low power consumption
- Less MCU processing required
- Improved tamper detection

7 PIR Configuration Settings

7.1 Channel Specifications

Channel 0 and channel 1 can be used for PIR sensing on the ProxFusion® IC's. As seen in Table 7-1, the other channels on the ProxFusion® IC's are dedicated to the different on-chip multi-sensors.

Table 7-1: PIR sensor – channel allocation

ProxFusion® IC	CH0	CH1	CH2	CH3	CH4	CH5
IQS620A	PIR or Touch	PIR or Touch	-	Temperature	HALL+	HALL-
IQS624	PIR or Touch	PIR or Touch	HALL	HALL	HALL	HALL



7.2 Hardware Configuration

Table 7-2 illustrates multiple options of configuring sensing (Rx) electrodes to realize different implementations.

Table 7-2: PIR hardware description

PIR Hardware configuration

One PIR
one touch

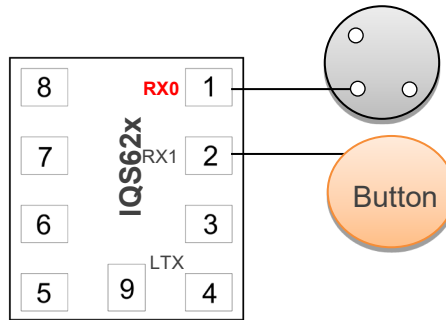

Two PIR
sensors

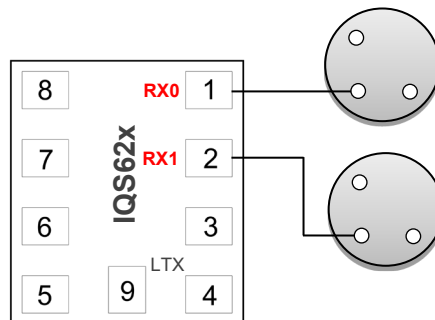



7.3 Register configuration

Table 7-3 shows the registers which need to be configured for this specific application. The recommended values are also given in the table. The thresholds can be changed according to the application.

Table 7-3: PIR sensor settings registers

Name	Description	Recommended setting	Value
ProxFusion Settings 0	Sensor mode and configuration of each channel.	Sensor mode should be set to projected mode, an appropriate RX should be chosen	0x11 0x12
ProxFusion Settings 1	Channel settings for the ProxSense sensors	Full ATI is recommended and big CS cap size	0x77 0x77
ProxFusion Settings 2	ATI settings for ProxSense sensors	ATI target should be more than ATI base to achieve an ATI	0x6A 0x6A
ProxFusion Settings 3*	Additional Global settings for ProxSense sensors	Enable CS divider.	0xE6 0xE6
ProxFusion Settings 4*	Filter settings	Enable bidirectional detection	0x21
ProxFusion Settings 5*	Advance sensor settings	None	0x03
Proximity threshold	Proximity Thresholds for all PIR channels	The proximity threshold should be adjusted according to application.	0x0D 0x0D
Touch threshold	Touch Thresholds for all PIR channels	The touch threshold should be adjusted according to application.	0x07 0x07
ProxFusion discrete UI halt time	Halt timeout setting for all capacitive channels	Set according to application	0x06

*Different on IQS624



7.4 Sensor data output and flags

The following registers should be monitored by the master to detect PIR sensor activations. The location of the registers in the Memory Map vary in the IQS62x series.

- a) The **ProxFusion UI flags (0x12)** provide more detail regarding the PIR sensor outputs. An individual prox and touch output bit for channel 0 and 1 is provided in the ProxFusion UI flags register.

ProxFusion UI flags (0x12)								
Bit Number	7	6	5	4	3	2	1	0
Data Access	-	-	R	R	-	-	R	R
Name	-	-	CH1_T	CH0_T	-	-	CH1_P	CH0_P

- b) The **Hall UI flags*** register provides the standard two-level activation output (prox and touch) as well as a **HALL_N/S** bit to indicate the magnet polarity orientation.

Hall-effect UI flags*								
Bit Number	7	6	5	4	3	2	1	0
Data Access	-	-	-	-	-	R	R	R
Name	-	-	-	-	-	HALL TOUT	HALL POUT	HALL N/S

- c) The **Hall UI output*** registers provide a 16-bit value of the Hall-effect amplitude detected by the sensor.

Hall-effect UI output*																
Bit Number	15	14	13	12	11	10	9	8	7	6	5	4	3	2	1	0
Data Access	Read															
Name	Hall-effect UI output high byte								Hall-effect UI output low byte							

* Not available on IQS624



When using the **IQS620A**, the following register can be monitored by the master to detect **temperature** related events.

- a) The **Temperature UI output** registers provide a 16-bit value of the temperature output magnitude as obtained by the current sensor measurement.

Temperature UI output																
Bit Number	15	14	13	12	11	10	9	8	7	6	5	4	3	2	1	0
Data Access								Read								
Name	Temperature UI output high byte							Temperature UI output low byte								

When using the **IQS624**, the following register can be monitored by the master for **hall rotation** measurements.

- a) The Degree Output (0x81-0x80). A 16-bit value for the degrees can be read from these registers. (0-360 degrees)

Degree output (0x81-0x80)																
Bit Number	15	14	13	12	11	10	9	8	7	6	5	4	3	2	1	0
Data Access								Read								
Name	Degree output high byte							Degree output low byte								



8 Application

Two PIR elements can be combined to sense human occupancy in a room. As seen in Figure 8-1 the two PIR elements can be set up to sense in different angles and can therefore sense movement in different places inside a room.



Figure 8-1: Dual PIR Setup

The hall-sensor on the IQS62x series can be used for a waterproof hall-switch application. The on-chip hall-sensors can be used instead of conventional waterproof switches to toggle between different UI's on the device. Figure 8-2 illustrates a setup where 3 different states can be used to implement different UI's on the device.

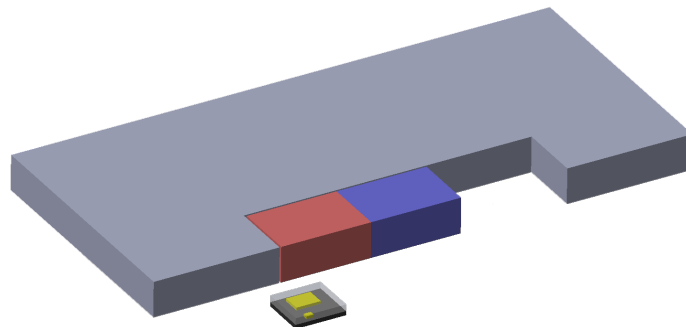

Figure 8-2: Hall-sensor slide switch



9 Power Consumption

The power consumption for battery applications is a crucial factor for design. The power consumed by the 2 PIR sensors and IQS62x were measured respectively and is shown in Table 9-1.

Table 9-1: PIR power consumption

Power mode	Conditions	Report rate	Min	Typical	Max	Unit
NP mode	VDD = 3.3V	10ms	131.28	134.40	138.71	µA
LP mode	VDD = 3.3V	48ms	24.93	30.21	32.32	µA
ULP mode	VDD = 3.3V	128ms	4.34	4.88	5.24	µA
2 PIR Sensors (D203S)	VDD = 5 V	-	22.63	23.80	24.27	µA

-These measurements were done on the setup described in this document

10 Signal-to-Noise Ratio

The signal-to-noise ratio of the ProxFusion® PIR configuration was calculated using a scanning platform. In order to perform repeatable tests, the PCB with PIR and ProxFusion IC was mounted on the axis of a stepper motor. A heat source was placed 3 m away from the scanning platform as seen in Figure 10-1.

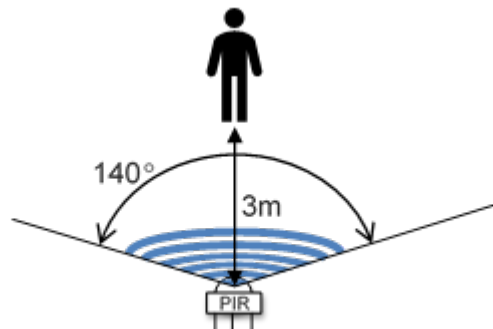

Figure 10-1: SNR Scanning Platform

The IC was configured to sample at a rate of 100 Hz. The target of the ProxFusion® IC translates to the gain of the signal and can be configured via I2C. A bias resistor (**R16/R17**) of 56kΩ was used with the D203S PIR. The SNR measured at a target of 512 was 33 dB. The target was increased to 1024 and the SNR was 38 dB. The SNR can be increased even more by decreasing the bias resistor. However, care should be taken if the device becomes too sensitive for environmental changes (i.e. temperature) when decreasing the bias resistor. The SNR of the ProxFusion® IC compares well to industry standard.



	USA	Asia	South Africa
Physical Address	11940 Jollyville Td Suite 120-S Austin TX 78750 USA	Rm 1227, Glittery City Shennan Rd Futian District Shenzhen, 518033 China	1 Bergsig Avenue Paarl 7646 South Africa
Postal Address	11940 Jollyville Td Suite 120-S Austin TX 78750 USA	Rm 1227, Glittery City Shennan Rd Futian District Shenzhen, 518033 China	PO Box 3534 Paarl 7620 South Africa
Tel	+1 512 538 1995	+86 755 8303 5294 ext 808	+27 21 863 0033
Email	info@azoteq.com	info@azoteq.com	info@azoteq.com

Visit www.azoteq.com
for a list of distributors and worldwide representation.

Patents as listed on www.azoteq.com/patents-trademarks/ may relate to the device or usage of the device.

AirButton®, Azoteq®, Crystal Driver®, IQ Switch®, ProxSense®, ProxFusion®, LightSense™, SwipeSwitch™, and the  logo are trademarks of Azoteq.

The information in this Datasheet is believed to be accurate at the time of publication. Azoteq uses reasonable effort to maintain the information up-to-date and accurate, but does not warrant the accuracy, completeness or reliability of the information contained herein. All content and information are provided on an "as is" basis only, without any representations or warranties, express or implied, of any kind, including representations about the suitability of these products or information for any purpose. Azoteq disclaims all warranties and conditions with regard to these products and information, including but not limited to all implied warranties and conditions of merchantability, fitness for a particular purpose, title and non-infringement of any third party intellectual property rights. Azoteq assumes no liability for any damages or injury arising from any use of the information or the product or caused by, without limitation, failure of performance, error, omission, interruption, defect, delay in operation or transmission, even if Azoteq has been advised of the possibility of such damages. The applications mentioned herein are used solely for the purpose of illustration and Azoteq makes no warranty or representation that such applications will be suitable without further modification, nor recommends the use of its products for application that may present a risk to human life due to malfunction or otherwise. Azoteq products are not authorized for use as critical components in life support devices or systems. No licenses to patents are granted, implicitly, express or implied, by estoppel or otherwise, under any intellectual property rights. In the event that any of the abovementioned limitations or exclusions does not apply, it is agreed that Azoteq's total liability for all losses, damages and causes of action (in contract, tort (including without limitation, negligence) or otherwise) will not exceed the amount already paid by the customer for the products. Azoteq reserves the right to alter its products, to make corrections, deletions, modifications, enhancements, improvements and other changes to the content and information, its products, programs and services at any time or to move or discontinue any contents, products, programs or services without prior notification. For the most up-to-date information and binding Terms and Conditions please refer to www.azoteq.com.